

FLOOR PLAN
SCALE: 3/8" = 1'-0"

CODE DATE = 2000 INTERNATIONAL CODE
CONSTRUCTION TYPE = B
OCCUPANCY MECHANICAL
ACCESSIBLE AREA 10000 SF
TOTAL AREA 5000 SF
PROVIDE 1 HOUR TENANT SEPARATION

Ex.H. B
INITIAL
H.N.
Q.N.
GDA

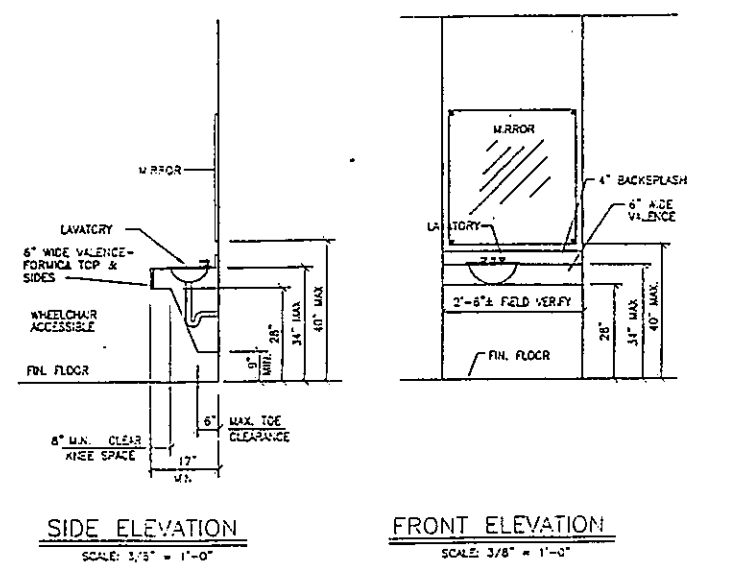

SIDE ELEVATION
SCALE: 3/8" = 1'-0"

FRONT ELEVATION
SCALE: 3/8" = 1'-0"

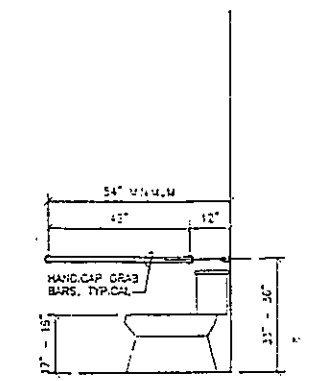

SIDE ELEVATION TOILET
SCALE: 3/8" = 1'-0"

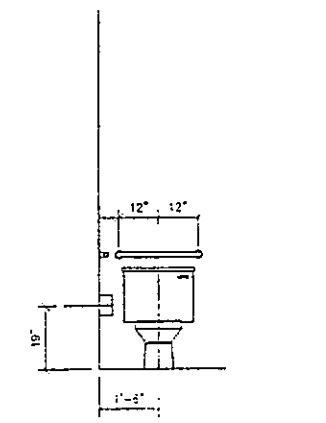

FRONT ELEVATION TOILET
SCALE: 3/8" = 1'-0"

HANDICAPPED BATHROOM CLEARANCES

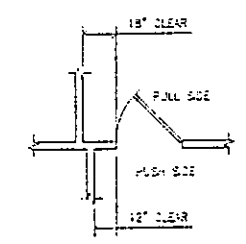

REQUIRED H/C CLEARANCES (ALL DOORS)
SCALE: 1/4" = 1'-0"

NOTE:
FIRE EXTINGUISHERS SHALL BE PROVIDED IN ACCORDANCE WITH LOCAL FIRE MARSHAL. EXTINGUISHER TYPE SHALL BE 2A, 10BC.

REVISIONS SHOWN THIS WAY	BY	DATE
1	EN	7/31/02
2	BT	8/13/02

FRANK A. DAGLEY & ASSOCIATES, INC.
CONSULTING ENGINEERS
MOBILE, ALABAMA
MOVIE GALLERY - MOFFAT ROAD
FLOOR PLAN
DATE SHOWN: 6/13/2002
PAGE: 2 of 9
PROJECT: FLP063
REV: C2-053